

700 class pintle chain

700 class pintle chains are able to withstand intense wear, which makes them the right chain for use with bucket elevators that carry sand and gravel in asphalt plants.

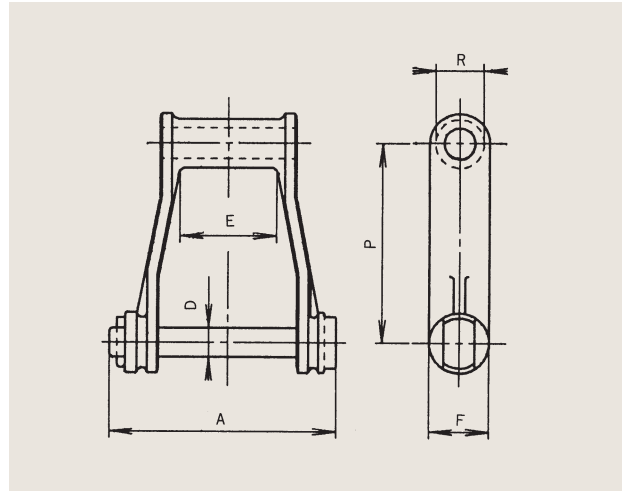

Chain No.	Pitch P		Dimensions (mm)					No. of links in one length	Average ultimate strength		Maximum allowable load		Mass (kg)	
	(mm)	(in)	A	D	R	E	F		(kN)	(kgf)	(kN)	(kgf)	1 length	1 m
710	119.89	4.720	135.0	17.5	29.0	60	36.0	25	123	12500	15.6	1600	27.51	9.17

K-2 attachments

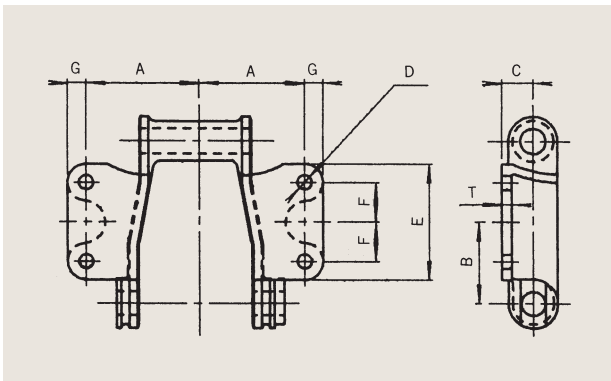

Chain No.	Dimensions (mm)							Mass (kg/link)	
	A	B	C	D	E	F	G		T
710	80	60	23	10.5	85	29	13.5	7.5	1.60