

Chains for Special Applications

Case conveyor chains and sprockets

Case conveyors run the chain inside a casing to convey loads. They can operate vertically or on an incline, as well as horizontally.

The optimum chain varies with the type of conveyor and the nature of the conveyed loads. Types include T type, U type, special UA type, UB type and UC type. For any type, we can produce special vane forms for efficient conveying.

Forged chains

These light and precise chains are strengthened by our unique heat treatment technology. They are suitable for long case conveyors.



T type attachment

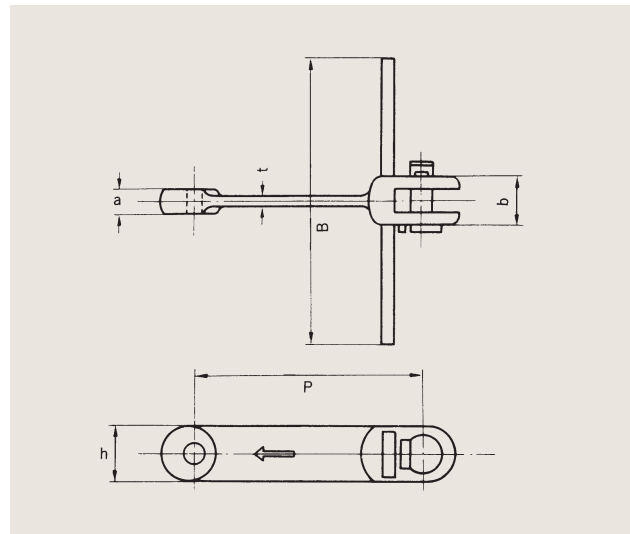

Note: Use in the direction indicated by the arrow.

Chain No.	Pitch P (mm)	Chain dimensions (mm)				Attachment dimension B (mm)	Average ultimate strength		Mass (kg/m)	Added mass per attachment link (kg)
		a	b	h	t		(kN)	(kgf)		
FT05125	120	10	21	26	6	125	49.0	5000	1.93	0.15
FT05150						150				0.16
FT05190						190				0.2
FT10125	150	15	32	34	8	125	98.1	10000	3.67	0.26
FT10150						150				0.31
FT10190						190				0.36
FT10240						240				0.47
FT10290						290				0.59
FT10340						340				0.9
FT15290	150	18	37	40	10	290	196	20000	5.6	0.7
FT20340	150	20	41	46	11	340	294	30000	7.6	1.26
FT20410						410				1.52
FT30410	200	20	41	46	12	410	392	40000	7.1	2.0
FT30480						480				2.4
FT40480	200	22	45	52	12	480	471	48000	9.0	2.7
FT40570						570				3.3
FT50570	200	26	54	54	14	570	569	58000	11.5	4.0
FT80640	260	39	90	80	20	640	785	80000	32.7	7.1
FT100690	260	39	90	90	20	690	981	100000	38.1	8.1

Note: We also manufacture special attachments.