

Chains for Special Applications

Steel chains

These chains are specially designed for case conveyors which convey powders. They have increased clearances between pins and bushes so that powder entering the space does not impair flexure. Twin-roller type chains were developed to prevent powders, granules and other conveyed particles from adhering between bushes and rollers and impairing roller rotation.

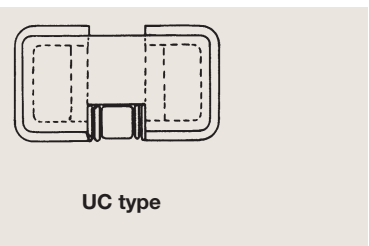
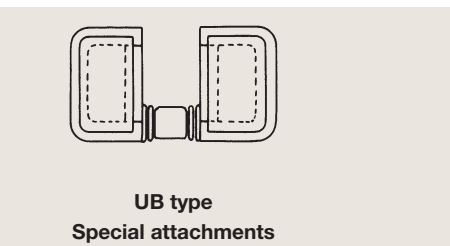
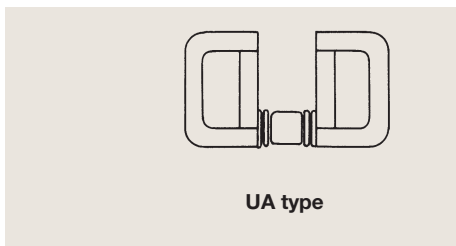
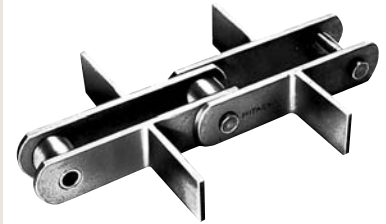
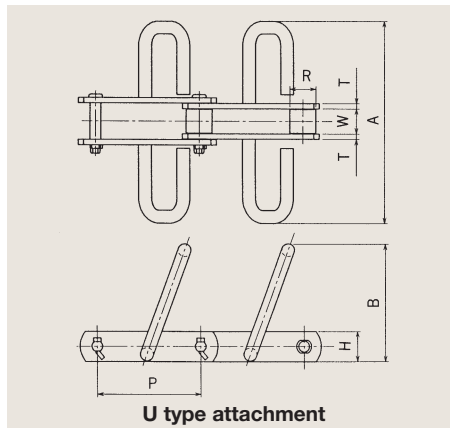
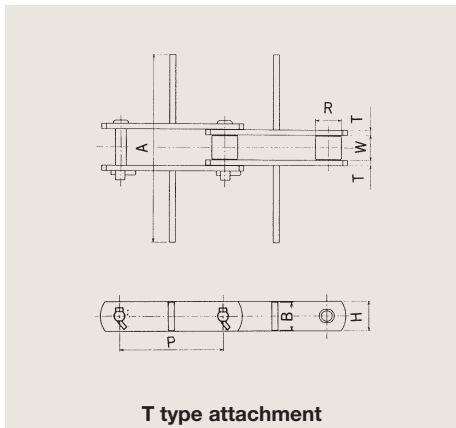

Special attachments

Twin roller type chains

We recommend special steel alloys for use with conveyors to carry raw materials and powders (cement, chemical fertilizers etc.), to resist wear. Consult us if the environment in which the chain will be used is wear or corrosive.

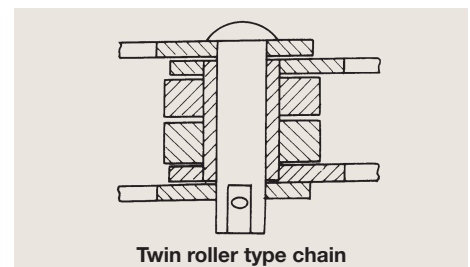

Chain No.	Chain pitch P (mm)	Roller outer Dia. R (mm)	Inner width W (mm)	Link plate		Attachment dimensions (mm)			Average ultimate strength		Mass (kg/m)	
				Height H (mm)	Thickness T (mm)	A	B		(kN)	(kgf)	T type	U type
							T type	U type				
HC10107	101.6	25.4	22.6	31.8	4.7	125	28	90	73.5	7500	5.1	9.3
HC10111	101.6	31.8	27.0	38.1	6.3	125	38	90	107.9	11000	8.1	11.3
						150		105			8.9	9.9
						180		120			8.9	14.1
HC15211	152.4	31.8	30.2	38.0	6.3	150	38	105	107.9	11000	8.0	9.0
HC15217	152.4	38.1	37.1	44.5	7.9	150	44	105	186.3	19000	10.8	12.0
						180		120			11.2	16.5
						230		140			13.0	18.6
						290		155			14.2	24.1
HC15222	152.4	44.5	37.1	50.8	9.5	180	50	160	245.2	25000	16.4	20.0
						230		120			16.6	20.5
HC20022	200	44.5	51.4	50.8	9.5	230	50	140	245.2	25000	15.4	19.3
						290		145			16.5	23.6
						340		160			18.9	26.0
						410		280			20.5	34.5
HC25031	250	50.8	57.2	63.5	9.5	340	60	150	304.0	31000	21.4	26.8
						410		280			23.0	32.4
						470		350			27.2	38.0
						570		390			33.0	39.2
						470		55			240	480.5
570	340	46.5	45.7									

Note: 1. We will manufacture cleaners and cups on request. 2. We can also manufacture special attachments.