

Cast Chains

H class pintle chains

These chains have ribs under the links that widen the sliding area when the chain slides over a trough or floor, reducing friction.

When using these chains, attach them so that the ribbed part of the chain is in contact with the sliding surface.

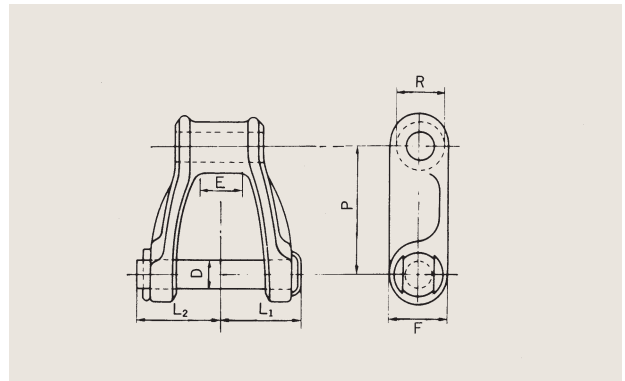

Chain No.	Pitch P		Dimensions (mm)						No. of links in one length	Average ultimate strength		Maximum allowable load		Mass (kg)	
	(mm)	(in)	L ₁	L ₂	D	R	E	F		(kN)	(kgf)	(kN)	(kgf)	1 length	1 m
H78	66.27	2.609	39.6	46.0	12.7	22.2	24	28.6	46	71.2	7260	10.5	1080	18.35	6.12
H82	78.11	3.075	48.9	51.6	14.3	31.0	28	31.8	39	88.9	9070	13.7	1400	29.30	9.77
H124	101.60	4.000	61.7	65.8	19.0	36.5	40	40.0	30	133.0	13600	22.2	2270	41.70	13.90

K-1 attachments

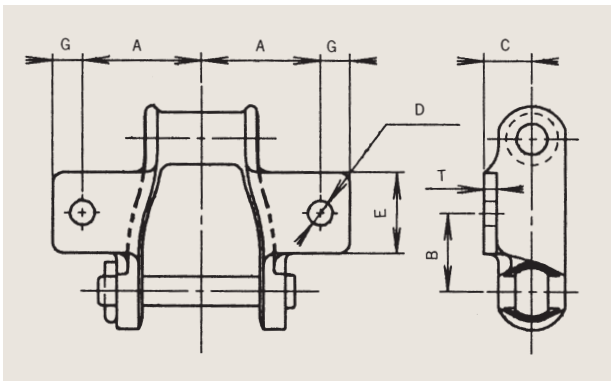

Chain No.	Dimensions (mm)							Mass (kg)	
	A	B	C	D	E	G	T	1 length	1 m
H78	50.8	33.8	20.6	10.5	35.0	12.7	5.6	24.69	8.23

K-2 attachments

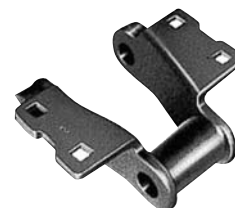
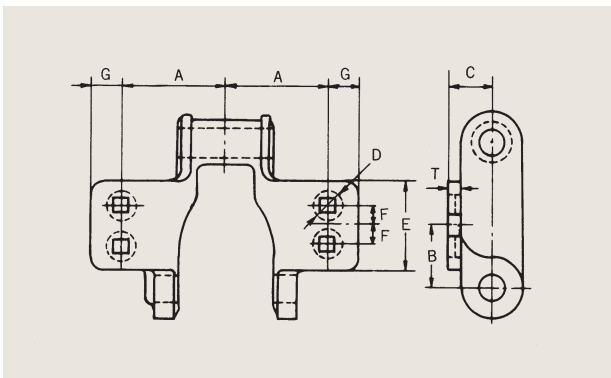

Chain No.	Dimensions (mm)								Mass (kg)	
	A	B	C	D	E	F	G	T	1 length	1 m
H82	54.0	35.7	22.2	10.5	55.6	16.7	15.9	7.9	35.9	11.97
H124	66.7	46.8	30.2	11.0	73.0	24.6	14.3	7.9	55.3	18.43