

Sprocket for forged chains

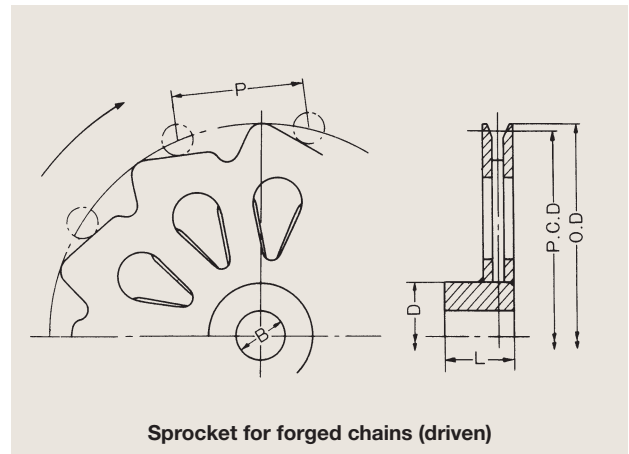
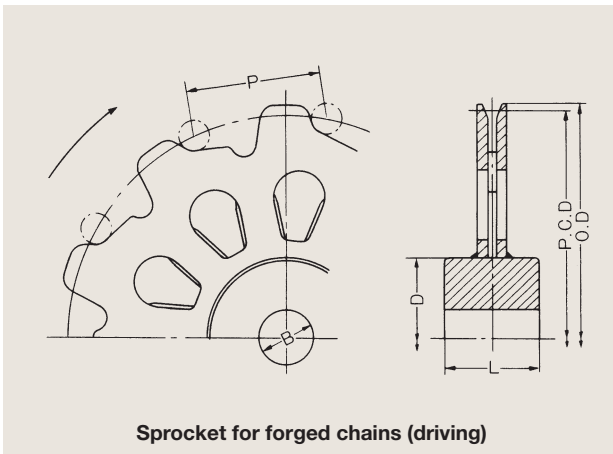

Sprocket for forged chains (drive end)

Chain No.	No. of teeth N	Pitch P (mm)	Pitch Circle Dia. P.C.D. (mm)	Outer Dia. O.D. (mm)	Maximum bore Dia. B (mm)	Hub (mm)		Mass (kg)
						Diameter D	Width L	
FT-10	8	150	392.0	416	85	135	90	24.8
	9		438.6	462				28
	10		485.4	510				31.5
FT-15	9	150	438.6	466	95	150	100	36
	10		485.5	512				40.5
	11		532.4	560				45.4
FT-20	9	150	438.6	470	110	180	120	52.9
	10		585.5	516				58.2
	11		532.4	564				64.2
FT-30	10	200	647.2	680	145	230	160	100
	11		709.9	742				113
	12		772.7	804				123
FT-40	10	200	647.2	682	160	260	180	139
	11		709.9	746				151
	12		772.7	810				163
FT-50	11	200	709.9	748	165	270	190	167
	12		772.7	810				180
	13		835.7	874				198

Note: We recommend that the idle end sprocket should be a toothed sprocket rather than a guide roller.

