

## Sprockets for sludge impellers

Ductile cast iron (FCD600) was previously the standard material for sprockets, but corrosion and wear within sewage water wore them out faster than stainless steel chains, so that only the sprockets had to be changed. We pursued research and improvement on the basis of our long experience, to develop our corrosion-resistant sprocket series (stainless steel assembled parts).

### Stainless steel sprockets

Stainless steel sprockets (SCS2) offer superior corrosion and wear resistance, minimizing the advance of wear and corrosion to extend sprocket lifespan.

Use of stainless steel sprockets also realizes synergistic benefits between chains and sprockets, further extending wear life.

Use of saver sprockets further reduces wear.



Saver type sprocket

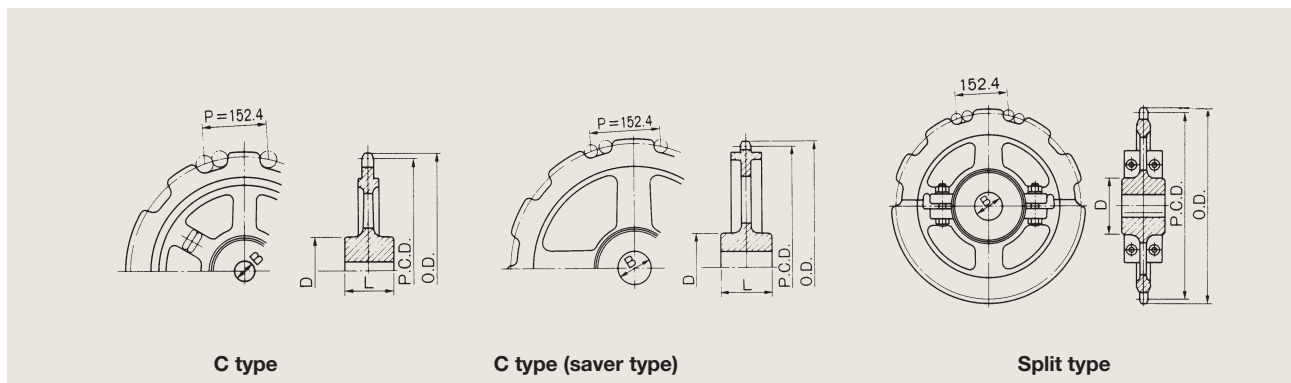

C type

C type (saver type)

Split type

Chain No.	No. of teeth N	Pitch circle Dia. P.C.D. (mm)	Outer Dia. O.D. (mm)	Type	Bore Dia. B (mm)		Hub (mm)		Mass (kg)
					Pilot bore	Maximum	Dia. D	Width L	
SAV15211-B	11	540.9	557	C type (saver type)	80	125	200	140	61
	11	540.9	557	Split type (saver type)	80	125	200	140	65
HSS15215-B	11	540.9	558	C type	80	125	200	140	51
	11	540.9	558	Split type	80	125	200	140	63
OSV15215-B	11	540.9	560	C type (saver type)	80	125	200	140	64
OSV15219-B	11	540.9	560	Split type (saver type)	80	125	200	140	70
SAV15215-B	11	540.9	560	C type	70	110	170	140	52
SAV15219-B	11	540.9	560	C type	90	125	200	140	58
HSS15219-B	11	540.9	560	Split type	80	125	200	140	68
SAV15219-B special	11	540.9	562	C type	110	150	230	130	56
HSS15219-B special	11	540.9	562	C type (saver type)	110	150	230	130	60
HEP720S	11	540.9	580	C type	80	125	200	140	65