

Steel drag chains

The barrels are welded to the link plates, making a simple and strong structure.

The chains themselves are heavy and their undersides are wide, so they can be used to convey hard, heavy materials.

The fronts of the barrels are vertical, so that they can push materials forward effectively, and so that the chain does not climb above the materials.

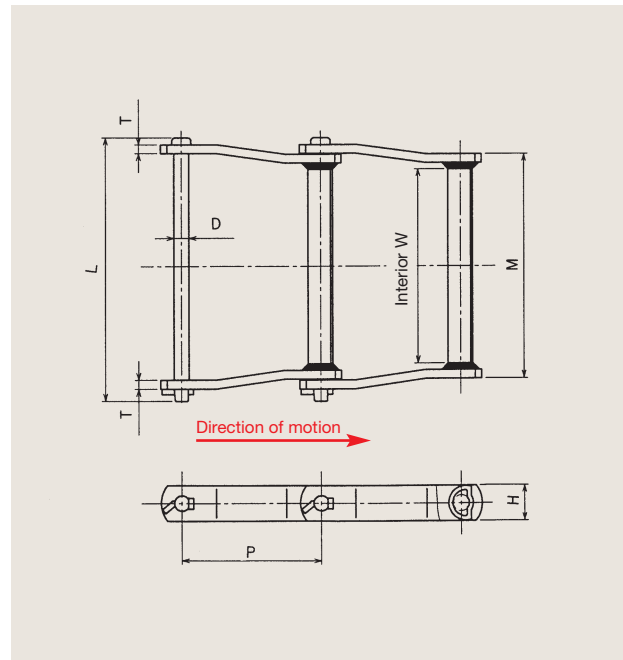
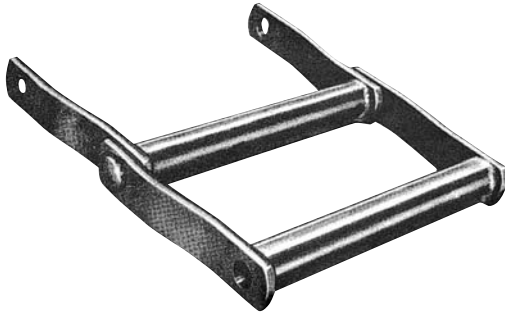

Chain No.	Pitch P (mm)	Pin		Link plate		M (mm)	W (mm)	Average ultimate strength		Mass (kg/m)
		Dia. D (mm)	Length L (mm)	Height H (mm)	Thickness T (mm)			(kN)	(kgf)	
WS102	127.0	19.1	240	38.1	9.5	198.4	165.1	177	18000	17.7
WS104	152.4	19.1	183	38.1	9.5	139.7	104.8	177	18000	12.7
WS110	152.4	19.1	307	38.1	9.5	263.5	228.6	177	18000	16.7
WS112	203.2	19.1	307	38.1	9.5	263.5	228.6	177	18000	16.6
WS116	203.2	19.1	406	44.5	9.5	358.7	303.2	226	23000	16.7
WS118	203.2	22.0	433	50.8	12.7	377.8	336.6	294	30000	38.4
WS120	152.4	22.0	320	50.8	12.7	262.0	222.2	294	30000	32.5
WS122	203.2	22.0	320	50.8	12.7	262.0	222.2	294	30000	26.0
WS480	203.2	22.0	382	50.8	12.7	325.0	280.2	294	30000	27.1