

Chains for Special Applications

Steel block chains

This kind of chain is mainly used in transfer conveyors, carrying billets and blooms in steelworks. They can also be used as draw bench chains with high loads.

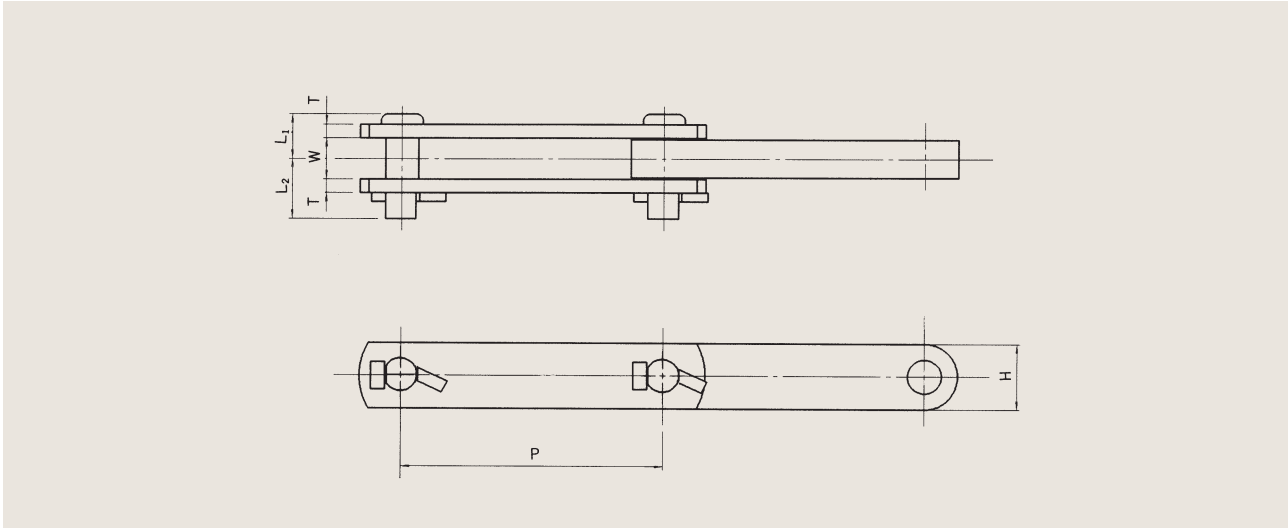

Chain No.	Pitch P (mm)	Pin Length		Link height H (mm)	Outer link thickness T (mm)	Width between outer links W (mm)	Average ultimate strength		Mass (kg/m)
		L ₁ (mm)	L ₂ (mm)				(kN)	(kgf)	
SBS3150	150	25.7	34.3	38.1	7.9	23.5	309	31500	7.0
SBS3200	200								6.8
SBS4150	150	28.4	35.6	44.5	7.9	27.0	397	40500	9.0
SBS4200	200								8.5
SBS5200	200	30.5	41.5	50.8	9.5	30.0	490	50000	12.5
SBS5250	250								12.1
SBS6200	200	32.5	43.5	57.2	9.5	34.0	618	63000	14.2
SBS6250	250								13.6
SBS6300	300								13.2
SBS7200	200	32.5	43.5	63.5	9.5	34.0	721	73500	16.2
SBS7250	250								15.5
SBS7300	300								15.2
SBS9200	200	35.5	46.5	63.5	12.7	38.0	883	90000	21.0
SBS9250	250								20.0
SBS9300	300								19.5
SBS11250	250	41.5	52.5	76.2	12.7	43.0	1118	114000	25.0
SBS11300	300								24.0
SBS14250	250	47.5	58.0	76.2	16.0	48.0	1373	140000	32.0
SBS14300	300								31.0

※We can also machine special dimensions.